

SPECIAL PROVISIONS**1. SCOPE:**

- 1.1. The purpose of this solicitation is obtain competitive bids for the purchase of Taskmaster® Grinders in accordance with the terms, conditions and specifications contained herein by the Alexandria Sanitation Authority (the "Authority").

2. PRICING:

- 2.1. All prices shall be F.O.B. DESTINATION and shall include all charges that may be incurred in fulfilling the terms of this IFB.
- 2.2. Prices submitted herein shall remain FIRM, regardless of make/model year changes that may occur as a result of manufacture/production changes, factory shutdowns, delivery schedules, etc.
- 2.3. Option prices shall be indicated as a price increase or decrease per item.
- 2.4. Option price will NOT be used in determining successful bidder. Award shall be made on the base unit.

3. DESCRIPTIVE LITERATURE REQUIRED:

- 3.1. Each bidder is required to furnish, with their bid, catalog cuts and/or descriptive literature, in DUPLICATE, properly labeled with the bid number, bid item number and bidder's name, with full illustrations and detailed specifications for each item offered as equal to the brand name specified. In addition, all differences in specifications from the brand name specified must be identified. Descriptive literature is required to establish details as to design, materials, method of manufacture, construction, assembly or operation, as appropriate for the purpose of bid evaluation and award. **FAILURE TO SUBMIT THE DESCRIPTIVE LITERATURE WILL BE CAUSE FOR REJECTION OF THE BID.**

4. DELIVERY/TIME OF PERFORMANCE:

- 4.1. The Authority requires that delivery be made at destination within the shortest time frame possible. Bidders must insert a definitive time frame, IN DAYS, on the Pricing Schedule within which delivery will be made after receipt of order (ARO). Indefinite terms such as "promptly," "stock," "without delay," etc., will not be given consideration. **THE FAILURE OF A BIDDER TO PROVIDE A DEFINITIVE DELIVERY TIME WILL RESULT IN THE DISQUALIFICATION OF THE BIDDERS BID IN ITS ENTIRETY OR FOR THE ITEM SPECIFIED.**
- 4.2. The Authority may pick up orders from the vendor when it is in the best interest of the Authority. In these instances the Contractor shall release the materials only to the designated representatives of the Authority authorized to place and pick up orders.
- 4.3. Delivery shall be made to the following location:

Alexandria Sanitation Authority
1500 Eisenhower Ave.
Alexandria, VA 22314

5. QUOTATION LIMITATION:

SPECIAL PROVISIONS (Continued)

- 5.1. Bidders shall offer only ONE ITEM AND PRICE for each line item bid. No alternatives will be accepted, unless requested by the Authority. If an "or equal" item is to be bid, the bidder must select the brand and model that meets or exceeds the specified item and submit their bid for that item. A discount price offered for a quantity purchase of the same manufacturer and model would not be considered a limitation; however, only the unit price requested will be considered in award.

6. INTERPRETATION OF BID:

- 6.1. Technical and contractual questions pertaining to this solicitation shall be directed to the following individuals:

Jeff Lee, CCCM
Contracts Specialist
Alexandria Sanitation Authority
1500 Eisenhower Ave.
Alexandria, VA 22314
P: 703-549-3381 ext. 2238
F: 703-549-9671
E: jeff.lee@alexsan.com

7. SUBMISSION OF BIDS:

- 7.1. Each bidder must use the attached Pricing Schedule for submitting their bid. Each bidder must show, as applicable, the manufacturer, style/stock number, delivery time, unit price and total price and/or percentage discount for each item for which a bid is submitted. **All bidders must return two (2) copies of the Cover Sheet, duly signed, and two (2) copies of Appendix B, keeping all remaining pages for your files.** By executing the Cover Sheet, the bidder acknowledges they have read this solicitation, understand it, and agrees to be bound by its terms and conditions. Bids may be submitted by mail or delivered in person. The receptionist at the following location prior to the date and time specified must receive all bids:

Alexandria Sanitation Authority
1500 Eisenhower Ave., Room J-231
Alexandria, VA 22314

BIDS RECEIVED AFTER THE DATE OR TIME OF OPENING WILL NOT BE CONSIDERED FOR CONTRACT AWARD AND SHALL BE RETURNED TO THE BIDDER.

- 7.2. Bidders are reminded that changes to the bid, in the form of addenda, are often issued between the issue date and within three (3) days before the opening/closing of the bid. All addenda **MUST** be signed and submitted to the address listed in Section 7.1 above before the time and date of the opening/closing of the bid or must accompany the bid. Addenda will be mailed, faxed or e-mailed to bidders who requested a bid package from the Authority or notified the Authority that a copy of the solicitation was downloaded from the web page. Bidders are encouraged to monitor the web page for the most current addenda at <http://alexsan.org/about/news-information/doing-business-with-asa/bid-opportunities/>.

8. CONTACT FOR ADMINISTRATION:

SPECIAL PROVISIONS (Continued)

- 8.1. In the event a contract is executed with your firm as a result of this solicitation, in the space provided on the Pricing Schedule please indicate the person(s) we may contact for prompt contract administration.

9. BID EVALUATION/CONTRACT AWARD:

- 9.1. All items listed in this solicitation will be awarded on the basis of a firm fixed price. The Authority reserves the right to award the contract in the aggregate or by line item depending upon what the Authority determines to be in its best interest.

10. CONTRACT INSURANCE PROVISIONS

- 10.1. The Contractor shall be responsible for its work and every part thereof, and for all materials, tools, equipment, appliances, and property of any and all description used in connection therewith. The Contractor assumes all risk of direct and indirect damage or injury to the property or persons used or employed on or in connection with the work contracted for, and of all damage or injury to any person or property wherever located, resulting from any action, omission, commission or operation by the Contractor, its employees, officers, directors, agents, contractors or subcontractors under the contract.

- 10.2. The Contractor shall, during the continuance of all work under the contract, provide the following:

- a. Maintain statutory Workers' Compensation and Employer's Liability insurance in limits of not less than \$1,000,000 to protect the Contractor from any liability or damages for any injuries (including death and disability) to any and all of its employees, including any and all liability or damage which may arise by virtue of any statute or law in force within the Commonwealth of Virginia.
- b. The Contractor agrees to maintain Commercial General Liability insurance in the amount of \$1,000,000 per occurrence/aggregate, to protect the Contractor, its subcontractors, and the interest of the Authority, its officers and employees against any and all injuries to third parties, including bodily injury and personal injury, wherever located, resulting from any action or operation under the Contract or in connection with the contracted work.

The General Liability insurance shall include the Broad Form Property Damage endorsement, in addition to coverages for explosion, collapse, and underground hazards, where required. Completed operations liability endorsement shall continue in force for three years following completion of the contract.

- c. The Contractor agrees to maintain owned, non-owned, and hired Automobile Liability insurance, in the amount of \$1,000,000 per occurrence/aggregate, including property damage, covering all owned, non-owned, borrowed, leased, or rented vehicles operated by the Contractor. In addition, all mobile equipment used by the Contractor in connection with the contracted work, will be insured under either a standard Automobile Liability policy, or a Commercial General Liability policy. The Garage Keeper's Liability coverage shall also be maintained where appropriate.
- d. Contractor agrees to maintain Contractors Liability insurance in the amount of \$500,000 per occurrence/aggregate to insure against loss due to liability imposed

SPECIAL PROVISIONS (Continued)

upon an owner/contractor for acts arising out of the operations of independent contractors/subcontractors or out of an owner's/contractor's supervisory activity.

e. Liability Insurance "Claims Made" basis:

If the liability insurance purchased by the Contractor has been issued on a "claims made" basis, the Contractor must comply with the following additional conditions. The limit of liability and the extensions to be included as described previously in these provisions, remain the same. The Contractor must either:

1. Agree to provide certificates of insurance evidencing the above coverage for a period of two years after final payment for the contract. This certificate shall evidence a "retroactive date" no later than the beginning of the Contractor's or sub-contractor's work under this contract, or
2. Purchase the extended reporting period endorsement for the policy or policies in force during the term of this contract and evidence the purchase of this extended reporting period endorsement by means of a certificate of insurance or a copy of the endorsement itself.

f. Liability insurance may be arranged by General Liability and Automobile Liability policies for the full limits required, or by a combination of underlying Liability policies for lesser limits with the remaining limits provided by an Excess or Umbrella Liability policy.

g. The Contractor agrees to provide insurance issued by companies admitted within the Commonwealth of Virginia, with the Best's Key Rating of at least A:VI.

h. European markets including those based in London, and the domestic surplus lines markets that operate on a non-admitted basis are exempt from this requirement provided that the Contractor's broker can provide financial data to establish that a market is equal to or exceeds the financial strengths associated with the A.M. Best's rating of A:VI or better.

i. Hold-harmless and Indemnification:

Section 63 of the General Conditions and Instructions to Bidders shall apply where an Authority form is used. If not, following paragraph shall be inserted:

"The Contractor hereby agrees to indemnify and hold harmless the Authority, its officers, agents and all employees and volunteers, from any and all claims for bodily injury, and personal injury and/or property damage, including cost of investigation, all expenses of litigation, including reasonable attorney fees, and the cost of appeals arising out of any claims or suits which result from errors, omissions, or negligent acts of the Contractor, his sub-contractors and their agents and employees."

j. The Contractor will provide an original, signed Certificate of Insurance citing the contract number and such endorsements as prescribed herein.

k. The Contractor will secure and maintain all insurance certificates of its sub-contractors, which shall be made available to the Authority on demand.

SPECIAL PROVISIONS (Continued)

- l. The Contractor will provide on demand certified copies of all insurance policies related to the contract within ten (10) business days of demand by the Authority. These certified copies will be sent to the Authority from the Contractor's insurance agent or representative.
- 10.3. No change, cancellation, or non-renewal shall be made in any insurance coverage without a forty-five (45) days written notice to the Authority. The Contractor shall furnish a new certificate prior to any change or cancellation date. The failure of the Contractor to deliver a new and valid certificate will result in suspension of all payments until the new certificate is furnished.
- 10.4. Compliance by the Contractor and all sub-contractors with the foregoing requirements as to carrying insurance shall not relieve the Contractor and all sub-contractors of their liabilities provisions of the contract.
- 10.5. Contractual and other liability insurance provided under this contract shall not contain a supervision, inspection or engineering services exclusion that would preclude the Authority from supervising and/or inspecting the project as to the end result. The Contractor shall assume all on-the-job responsibilities as to the control of persons directly employed by it and of the sub-contractors.
- 10.6. Nothing contained in the specifications shall be construed as creating any contractual relationship between any sub-contractor and the Authority. The Contractor shall be as fully responsible to the Authority for the acts and omissions of the sub-contractors and of persons employed by them as it is for acts and omissions of person directly employed by it.
- 10.7. Precaution shall be exercised at all times for the protection of persons (including employees) and property.
- 10.8. The Contractor and all subcontractors are to comply with the Occupational Safety and Health Act of 1970, Public Law 91-596, as it may apply to this contract.
- 10.9. The Authority, its officers and employees shall be named as an "additional insured" in the Automobile and General Liability policies and it shall be stated on the Insurance Certificate that this coverage "is primary to all other coverage the Authority may possess."
- 10.10. If an "ACORD" Insurance Certificate form is used by the Contractor's insurance agent, the words, "endeavor to" and "...but failure to mail such notice shall impose no obligation or liability of any kind upon the company" in the "Cancellation" paragraph of the form shall be deleted or crossed out.

11. PURCHASE ORDER:

- 11.1. A purchase order for the items listed in this IFB will be issued shortly after contract award and will become an integral part of the resulting contract. The purchase order indicates that sufficient funds have been obligated as required by Title 15.2-1238 of The Code of the Commonwealth of Virginia, and assures distribution of the necessary receiving reports.
- 11.2. When a separate contract exists between the Contractor and the Authority, the purchase order does not supersede any provision of the resulting contract. Performance time and date are determined solely by the contract and any modifications.

SPECIAL PROVISIONS (Continued)

11.3. Services/Supplies are not to begin until receipt of the purchase order or other notification by the Purchasing Agent to proceed.

11.4. The Authority has the capability to issue purchase orders electronically and transmit them to vendors by fax. For more information about the Fax Purchase Order program, call (703) 549-3381.

12. ADDITIONAL QUANTITIES:

12.1. By mutual agreement with the Contractor, the Authority may purchase additional quantities of like description at the same price, terms, and conditions for the duration of the production model year, or one year from the date of award of the contract.

13. CANCELLATION OF ORDERS:

13.1. Purchases made under this contract are for readily available supplies. Time is of the essence in furnishing the items ordered. The Authority reserves the right to cancel the order and/or to refuse delivery if the items ordered are not furnished within the period of time specified in this contract.

14. EMERGENCY PURCHASES:

14.1. Should the Contractor be unable to furnish the required item within the period of time specified in the contract, the Authority reserves the right to make emergency purchases from other sources.

15. INVOICING PROCEDURE:

15.1. The Contractor shall submit a Summary Invoice once each month, listing the Sales/Delivery Ticket numbers covering deliveries made during the monthly billing period and submitted to the BILL TO address shown on the purchase order, blanket order (Call Order Number) or the small order. The invoice must be accompanied by one copy of each signed Sales/Delivery Ticket.

15.2. The invoice shall contain the applicable purchase order number, name of the goods with the applicable stock number, quantity ordered, quantity shipped, quantity back-ordered (if applicable), the name of the Contractor or other supplier, blanket order (call order number) or small order number, and the name of the Authority receiving the supplies. Payment will be made once each month.

16. LISTING OF EXCEPTIONS:

16.1. All exceptions to contract specifications must be itemized. Details concerning the exception must be clearly explained. Each exception will be considered by the Authority as to the degree of impact and total effect on the bid.

16.2. The Authority assumes that silence to an exception indicates that the item will comply with the specifications. Should the item not comply, and the exception is not indicated, then the item will be rejected when delivered. All items shall be given a general inspection for material, workmanship, and compliance with specifications prior to acceptance. Should the item not comply and exception not taken, the Contractor shall be held responsible to fulfill that specification. Acceptance is not final until all specifications, with concurrence to

SPECIAL PROVISIONS (Continued)

exceptions, are met. The submission of literature will NOT constitute the taking of an exception nor honor any specification changes.

17. DEVIATION FROM SPECIFICATIONS:

- 17.1. Brand name(s) and/or catalog number(s) are given for purposes of identification and to denote the standard of quality desired, and do not, in any way, restrict bidders to a specific make and manufacturer. If there is any deviation in the pack, source, quality, etc., of an item bid, from that prescribed in the specifications, the appropriate line in the specifications will be ruled out and the substitution clearly indicated.

18. APPROXIMATIONS:

- 18.1. Any specification with an approximate (approx.) measurement shall be deemed acceptable if within 10% plus or minus the specified measurement.

19. USE OF CONTRACT BY OTHER PUBLIC BODIES:

- 19.1. Reference Section 76, General Conditions and Instructions to Bidders. Extension of Contract: Bidders are advised that the resultant contract(s) may be extended, with the authorization of the bidder, to other public bodies, or public agencies or institutions of the United States to permit their use of the contract at the same prices and/or discounts and terms and conditions of the resulting contract. If any other public body decides to use the final contract, the Contractor(s) must deal directly with that public body concerning the placement of orders, issuance of the purchase orders, contractual disputes, invoicing and payment. The Authority acts only as the "Contracting Agent" for these public bodies. Failure to extend a contract to any public body will have no effect on consideration of your bid (See Appendix B for sample listing).
- 19.2. It is the awarded vendor's responsibility to notify the jurisdictions and political subdivision of the availability of the contract(s).
- 19.3. Other public bodies desiring to use this contract will need to make their own legal determinations as to whether the use of this contract is consistent with their laws, regulations, and other policies.
- 19.4. Each public body has the option of executing a separate contract with the Contractor(s). Public bodies may add terms and conditions required by statute, ordinances, and regulations, to the extent that they do not conflict with the contracts terms and conditions. If, when preparing such a contract, the general terms and conditions of a public body are unacceptable to the Contractor, the Contractor may withdraw its extension of the award to that public body.
- 19.5. The Authority shall not be held liable for any costs or damages incurred by another public body as a result of any award extended to that public body by the Contractor.

20. ORDER OF PRECEDENCE:

- 20.1. In the event of conflict, the following order of precedence will be followed: (1) the Acceptance Agreement (provided at contract award) will take precedence over the other contract documents, and (2) the Special Provisions of this contract shall take precedence over the (3) General Conditions and Instructions to Bidders (Appendix A).

SPECIAL PROVISIONS (Continued)**21. SUBCONTRACTING:**

- 21.1. If one or more subcontractors are required, the Contractor is encouraged to utilize small, minority-owned, and women-owned business enterprises. For assistance in finding subcontractors, contact the Virginia Department of Business Assistance <http://www.dba.state.va.us>; the Virginia Department of Minority Business Enterprise <http://www.dmb.state.va.us/>; local chambers of commerce and other business organizations.
- 21.2. As part of the contract award, the prime contractor agrees to provide the names and addresses of each subcontractor, that subcontractor's status as defined by the Authority, as a small, minority-owned and/or woman-owned business, and the type and dollar value of the subcontracted goods/services provided. Reference Appendix B to this solicitation.

22. NEWS RELEASES BY VENDORS:

- 22.1. As a matter of policy, the Authority does not endorse the products or services of a contractor. A contractor without the prior written approval of the Authority will not make news releases concerning any resultant contract from this solicitation. All proposed news releases will be routed to the Purchasing Agent for review and approval.

23. AMERICANS WITH DISABILITIES ACT REQUIREMENTS:

- 23.1. The Authority is committed to a policy of nondiscrimination in all of the Authority's programs, services, and activities and will provide reasonable accommodations upon request. Bidders requesting special accommodations should call the Purchasing Agent at (703) 549-3381 x2203. Please allow seven (7) working days in advance of the event to make the necessary arrangements.
- 23.2. The Authority is fully committed to the Americans with Disabilities Act (ADA) which guarantees non-discrimination and equal access for persons with disabilities in employment, public accommodations, transportation, and all programs, activities and services of the Authority. The Authority's contractors, subcontractors, vendors, and/or suppliers are subject to this ADA policy. All individuals having any contractual agreement with the Authority must make the same commitment.
- 23.3. Your acceptance of this contract acknowledges your commitment and compliance with ADA.

24. PROVISIONS REQUIRED BY LAW DEEMED INSERTED:

- 24.1. Each and every provision of laws and clauses required by law to be inserted in this contract shall be deemed to be inserted herein and hereby incorporated by reference and the contract shall be read and enforced as though it were included herein and if through mistake or otherwise, any such provision is not inserted or not correctly inserted, then upon the application of either party the contract shall forthwith be physically amended to make such insertion.

TECHNICAL SPECIFICATIONS**Item Description:****TASKMASTER® GRINDERS, Model TM851208:**

Drop-in design housing for fast & easy maintenance without breaking pipe connections (ASA will use existing drive & control min: 75 GPM; max: 200)

Cutter cartridge technology: patented, high strength tooth cam cutters, 4140 H.T.

Nom. 8" x 12" cutting chamber

8" ansi flange housing – 150# bolt pattern – D.1.

Mechanical seals: TC vs. TC 90 psi max

2" hexagonal shafting, 4140 H.T.

23.25" flange to flange dimension

Gear Reducers

Vertical down – flange mount

For C face motor, less motor

Ratio: 29:1 suitable for 3-5 hp

Reducer Adapters

to fit existing motor (approx. height – 8 inches)

Expansion Joint Spool

piece, 8" x 8" FF, superflex style 1000, neo tube & cover, reinforced SGL arch filled, 150#, drilled flanges with 8" 150# retaining rings and control units (2 rods)

Coupling Halfs for Reducers

3.75 OD

1.5 ID

3/8" key

3.19 length

PARTS LIST			
ITEM	QTY	DESCRIPTION	
1	1	TASKMASTER LESS DRIVE	TM851211
2			
3	1	REDUCER	GR00143
4	1		
5	1	COUPLING HALF, REDUCER	FM00015AT
10	2	SET SCREW 3/8-16 x 1/2	SS061608S
11	4	SCREW, 1/2-13 x 1 1/2 HHCS	HC081324S
12	4	LOCKWASHER, 1/2	LW08S
13	4	SCREW, 3/8-16 x 1 1/4	HC081620S
14	4	LOCKWASHER, 3/8	LW06S
15	2	LIFTING EYE NUT, 3/8-16	EN0816
16	2	HEX BOLT 3/8-16 x 2", GRADE 8	HC081632HT
17	2	LOCKWASHER 3/8 HI-STRENGTH	LW06HT
301	1	CONTROL	EC
400	1	SPOOL, 4.75'LG	SS80179A

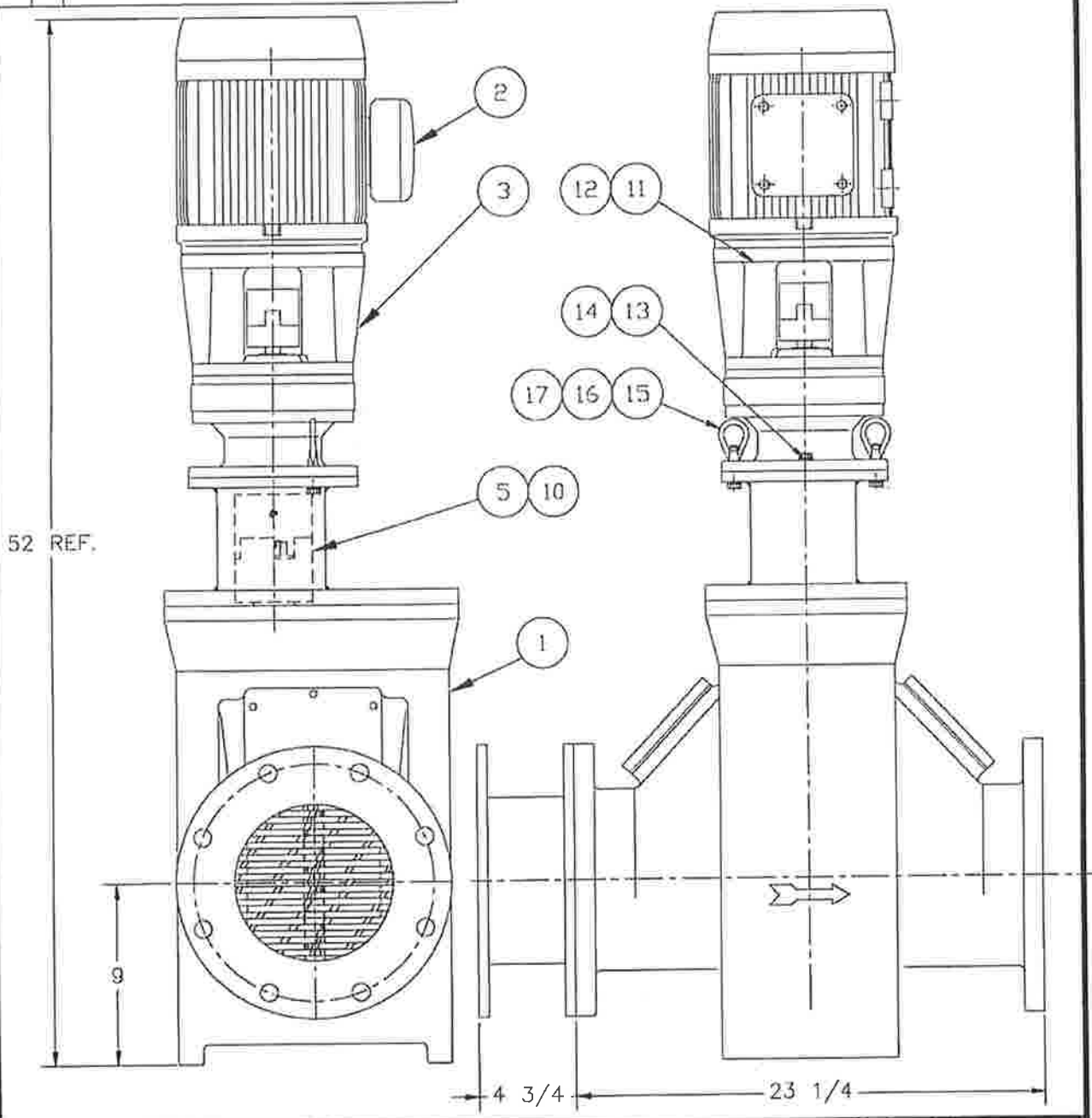

VM3611T Performance Data

Winding = 35WGY334

RATING - NOMINALS

Rated Output	3
Volts	208-230/460
Full Load Amps	8.5-8.2/4.1
Speed	1725
Hertz	60
Phase	3
NEMA Design Code	B
LR KVA Code	F
Efficiency	84.0
Power Factor	82
Service Factor	1.15
Rating - Duty	40C AMB-CONT

CHARACTERISTICS

Break Down Torque	41.0
Locked-Rotor Torque	31.0
Starting Current	35.0
No-Load Current	2.20
Line-line Resistance @ 25 degrees C	5.48
Temperature Rise, in degrees C @ F.L.	85

LOAD CHARACTERISTICS - TESTED

% of Rated Load	25	50	75	100	125	150	S.F
Power Factor	41	63	75	82	86	89	85
Efficiency	72.0	81.0	83.0	84.0	83.0	81.0	83.0
Speed (rpm)	1785	1770	1750	1735	1720	1695	1725
Line Amperes	2.40	2.80	3.40	4.10	4.90	5.80	4.60

ALEXANDRIA SANITATION AUTHORITY

GENERAL CONDITIONS AND INSTRUCTIONS TO BIDDERS

(Vendor: The general rules and conditions which follow apply to all purchases and become a definite part of each formal solicitation and resulting contract award issued by the Authority, unless otherwise specified. Bidders or their authorized representatives are expected to inform themselves fully as to the conditions, requirements, and specifications before submitting bids; failure to do so will be at the bidder's own risk and relief cannot be secured on the plea of error).

Subject to all State and local laws, policies, resolutions, and regulations and all accepted rules, regulations and limitations imposed by legislation of the Federal Government, bids on all solicitations issued by the Authority will bind bidders to applicable conditions and requirements herein set forth unless otherwise specified in the solicitation.

1. AUTHORIZATION: All solicitations, contracts and purchase orders issued by the Authority may be negotiated, placed or modified by either the Purchasing Agent or the General Manager of the Authority only. In the discharge of these responsibilities, the Purchasing Agent and General Manager may be assisted by assigned buyers. Unless specifically delegated by the Purchasing Agent or General Manager, no other officer or employee of the Authority is authorized to order supplies or services, enter into purchase negotiations or contracts, or in any way obligate the Authority for indebtedness. Any purchase ordered or contract made which is contrary to these provisions and authorities shall be of no effect and void and the Authority shall not be bound thereby.

2. DEFINITIONS:

AUTHORITY: Alexandria Sanitation Authority.

BID: The offer of a bidder to provide specific goods or services at specified prices and/or other conditions specified in the solicitation.

BIDDER/OFFEROR: Any individual, company, firm, corporation, partnership or other organization bidding on solicitations issued by the Purchasing Agent and offering to enter into contracts with the Authority. The term "bidder" will be used throughout this document and shall be construed to mean "offeror" where appropriate.

CONTRACTOR: Any individual, company, firm, corporation, partnership or other organization to whom an award is made by the Authority.

GOODS: All material, equipment, supplies, printing, and automated data processing/information technology hardware and software.

INFORMALITY: A minor defect or variation of a bid or proposal from the exact requirements of the IFB or the RFP which does not affect the price, quality, quantity or delivery schedule for the goods, services or construction being procured.

INVITATION FOR BID (IFB): A request which is made to prospective suppliers (bidders) for their quotation on goods or services desired by the Authority. The issuance of an IFB will contain or incorporate by reference the specifications and contractual terms and conditions applicable to the procurement.

GENERAL CONDITIONS AND INSTRUCTIONS TO BIDDERS (Continued)

OPEN MARKET PROCUREMENT (OMP): A method of competitive bidding for the purchase or lease of goods, non-professional services or for the purchase of insurance, construction, or construction management when the estimated cost thereof shall be less than \$50,000.

PROFESSIONAL & CONSULTANT SERVICES: Any type of professional service which is either: (a) performed by an independent contractor within the practice of accounting, actuarial services, architecture, dentistry, land surveying, landscape architecture, law, medicine, optometry, pharmacy, or professional engineering (which shall be procured as set forth in the Code of Virginia §2.2-4301 in the definition of competitive negotiation at paragraph 3(a), and in conformance with the Authority's Purchasing Resolution), or (b) any other type of similar contractual service (including consultants), required by the Authority but not furnished by its own employees, which is in its nature so unique that it should be obtained by negotiation on the basis of demonstrated competence and qualification for the type of professional service required and at fair and reasonable compensation rather than by competitive sealed bidding.

PURCHASING AGENT: The Purchasing Agent employed by the Authority.

REQUEST FOR PROPOSAL (RFP): A request for an offer from prospective offerors which will indicate the general terms which are sought to be procured from the offeror. The RFP will specify the evaluation factors to be used and will contain or incorporate by reference other contractual terms and conditions applicable to the procurement.

RESPONSIBLE BIDDER/OFFEROR: An individual, company, firm, corporation, partnership or other organization having the capability in all respects to perform fully the contract requirements, and also having the moral and business integrity and reliability which will assure good faith performance, and having been prequalified, if required (Reference Section 23, General Conditions and Instructions to Bidders).

RESPONSIVE BIDDER/OFFEROR: An individual, company, firm, corporation, partnership or other organization having submitted a bid which conforms in all material respects to the IFB or RFP.

SERVICES: Any work performed by an independent contractor wherein the service rendered does not consist primarily of acquisition of equipment or materials, or the rental of equipment, materials and supplies.

SOLICITATION: The process of notifying prospective bidders that the Authority wishes to receive bids on a set of requirements to provide goods or services. The notification of Authority's requirements may consist of public advertising (newspaper, Authority's Web Site, or other electronic notification), the mailing of Notices of Solicitation, IFB or RFP, the public posting of notices, issuance of an Open Market Procurement (OMP), or telephone calls to prospective bidders.

STATE: Commonwealth of Virginia.

CONDITIONS OF BIDDING

3. BID FORMS: Unless otherwise specified in the solicitation, all bids shall be submitted on the forms provided, to include the bid Cover Sheet and Pricing Schedule(s), properly signed in ink in the proper spaces and submitted in a sealed envelope provided with the solicitation. The item pages of the Pricing Schedule which do not include any items for which a bid is required need not

GENERAL CONDITIONS AND INSTRUCTIONS TO BIDDERS (Continued)

be included in the submission of a bid.

Should the bid prices and/or any other submissions differ on the copy of the submitted bid, the ORIGINAL copy shall prevail.

4. LATE BIDS & MODIFICATIONS OF BIDS:

- a. Any bid/modification received at the office designated in the solicitation after the exact time specified for receipt of the bid/modification is considered a late bid/modification. A late bid/modification will not be considered for award except under the following conditions only:
 - i. It was sent by registered or certified mail not later than the fifth (5th) calendar date prior to the date specified for receipt of the bid/modification; or
 - ii. The bid/modification was sent by mail and it is determined by the Purchasing Agent that the late receipt was due solely to mishandling by the Authority after receipt at the address specified in the solicitation.
- b. If the Authority declares administrative or liberal leave, scheduled bid openings or receipt of proposals will be extended to the next business day.
- c. The time of receipt of bids at the specified location is the time-date stamp of such location on the bid wrapper or other documentary evidence of receipt maintained by the specified location.
- d. A late hand-carried bid, or any other late bid not submitted by mail, shall not be considered for award.

5. WITHDRAWAL OF BIDS:

- a. A bidder for a public construction contract, other than a contract for construction or maintenance of public highways, may withdraw his or her bid from consideration if the price bid was substantially lower than the other bids due solely to a mistake therein, provided the bid was submitted in good faith, and the mistake was a clerical mistake as opposed to a judgment mistake, and was actually due to an unintentional arithmetic error or an unintentional omission of a quantity of work, labor or material made directly in the compilation of a bid, which unintentional arithmetic error or unintentional omission can be clearly shown by objective evidence drawn from inspection of original work papers, documents and materials used in the preparation of the bid sought to be withdrawn. If a bid contains both clerical and judgment mistakes, a bidder may withdraw his bid from consideration if the price bid would have been substantially lower than the other bids due solely to the clerical mistake, that was an unintentional arithmetic error or an unintentional omission of a quantity of work, labor or material made directly in the compilation of a bid which shall be clearly shown by objective evidence drawn from inspection of original work papers, documents and materials used in the preparation of the bid sought to be withdrawn. The bidder shall give notice in writing to the Purchasing Agent of his or her claim of right to withdraw his or her bid within two (2) business days after the conclusion of the bid opening procedure and shall submit original work papers with such notice.

GENERAL CONDITIONS AND INSTRUCTIONS TO BIDDERS (Continued)

- b. A bidder for a contract other than for public construction may request withdrawal of his or her bid under the following circumstances:
 - i. Requests for withdrawal of bids prior to opening of such bids shall be transmitted to the Purchasing Agent in writing.
 - ii. Requests for withdrawal of bids after opening of such bids but prior to award shall be transmitted to the Authority Purchasing Agent, in writing, accompanied by full documentation supporting the request. If the request is based on a claim of error, documentation must show the basis of the error. Such documentation may take the form of supplier quotations, vendor work sheets, etc. If bid bonds were tendered with the bid, the Authority may exercise its right of collection.
- c. No bid may be withdrawn under this paragraph when the result would be the awarding of the contract on another bid of the same bidder or of another bidder in which the ownership of the withdrawing bidder is more than five (5%) percent.
- d. If a bid is withdrawn under the authority of this paragraph, the lowest remaining bid shall be deemed to be the low bid.
- e. No bidder who is permitted to withdraw a bid shall, for compensation, supply any material or labor to or perform any subcontract or other work agreement for the person or firm to whom the contract is awarded or otherwise benefit, directly or indirectly, from the performance of the project for which the withdrawn bid was submitted.
- f. If the Authority denies the withdrawal of a bid under the provisions of this paragraph, it shall notify the bidder in writing stating the reasons for its decision and award the contract to such bidder at the bid price, provided such bidder is a responsible and responsive bidder.
- g. Work papers, documents, and materials submitted in support of a withdrawal of bids may be considered as trade secrets or proprietary information subject to the conditions of the Virginia Freedom of Information Act.

6. ERRORS IN BIDS: When an error is made in extending total prices, the unit bid price will govern. Erasures in bids must be initialed by the bidder. Carelessness in quoting prices, or in preparation of bid otherwise, will not relieve the bidder. Bidders are cautioned to recheck their bids for possible error. Errors discovered after public opening cannot be corrected and the bidder will be required to perform if his or her bid is accepted.

7. MAILING OF BIDS: All bids and proposals submitted in response to a solicitation from the Authority shall be submitted either (a) in the special mailing envelope provided by the Authority; or (b) have the solicitation number, subject, and date/time of opening/closing clearly marked on the outside of any other wrapper used.

8. COMPLETENESS: To be responsive, a bid must include all information required by the solicitation.

9. ACCEPTANCE OF BIDS/BINDING 90 DAYS: Unless otherwise specified, all formal bids submitted shall be binding for ninety (90) calendar days following bid opening date, unless

GENERAL CONDITIONS AND INSTRUCTIONS TO BIDDERS (Continued)

extended by mutual consent of all parties.

10. CONDITIONAL BIDS: Conditional bids are subject to rejection in whole or in part.

11. BIDS FOR ALL OR PART: Unless otherwise specified by the Purchasing Agent or by the bidder, the Purchasing Agent reserves the right to make award on all items in the aggregate or on any of the items on an individual basis, whichever is in the best interest of the Authority. A bidder may restrict his or her bid to consideration in the aggregate by so stating but shall name a single unit price on each item bid. Any bid in which the bidder names a total price for all the articles without quoting a unit price for each and every separate item may not be considered for award.

12. TIME FOR RECEIVING BID: Bids received prior to the time of opening will be securely kept, unopened. The representative of the Purchasing Agent assigned to open them will decide when the specified time has arrived, and no bid received thereafter will be considered, except as provided in Section 4, General Conditions and Instructions to Bidders. No responsibility will attach to the Purchasing Agent or his or her representative for the premature opening of a bid not properly addressed and identified. Unless specifically authorized in the solicitation, telegraphic, electronic, or facsimile bids/modifications will not be considered.

13. BID OPENING: All bids received in response to an IFB will be opened at the date, time and place specified, read publicly, and made available for inspection as provided in Section 69, General Conditions and Instructions to Bidders. Tabulations of bids received are posted on the Authority's Bulletin Board as well as the Authority's web site: <http://alexsan.org/about/news-information/doing-business-with-asa/bid-opportunities/>.

Proposals received in response to a RFP will be made available as provided in Section 69, General Conditions and Instructions to Bidders.

14. OMISSIONS & DISCREPANCIES: Any items or parts of any equipment listed in this solicitation which are not fully described or are omitted from such specification, and which are clearly necessary for the completion of such equipment and its appurtenances, shall be considered a part of such equipment although not directly specified or called for in the specifications.

Should a bidder find discrepancies or ambiguities in, or omissions from, the solicitation, including the drawings and/or specifications, he or she shall notify the Purchasing Agent at least five (5) days prior to the date set for the opening of bids. If necessary, the Purchasing Agent will send a written addendum for clarification to all bidders no later than three (3) days before the date set for opening of bids. Notifications regarding specifications will not be considered if received within five days of the date set for opening of bids.

15. RESPONSE TO SOLICITATIONS: In the event a vendor cannot submit a bid on a solicitation, he or she is requested to return the solicitation cover sheet with an explanation as to why he or she is unable to bid on these requirements.

16. BIDDER INTERESTED IN MORE THAN ONE BID: If more than one bid is offered by any one party, either directly or by or in the name of his or her clerk, partner, or other persons, all such bids may be rejected. A party who has quoted prices on work, materials, or supplies to a bidder is not thereby disqualified from quoting prices to other bidders or firms submitting a bid directly for the work, materials or supplies.

GENERAL CONDITIONS AND INSTRUCTIONS TO BIDDERS (Continued)

17. TAX EXEMPTION: The Authority is exempt from the payment of any federal excise or any Virginia sales tax. The price bid must be net, exclusive of taxes. However, when under established trade practice any federal excise tax is included in the list price, a bidder may quote the list price and shall show separately the amount of federal tax, either as a flat sum or as a percentage of the list price, which shall be deducted by the Authority. The Authority's Federal Excise Tax Exemption Number is A-147650. Contractors located outside the Commonwealth of Virginia are advised that when materials are picked up by the Authority at their place of business, they may charge and collect their own local/state sales tax. Materials used in the performance of construction contracts are subject to Virginia Sales/Use Tax as described in Section 630-10-27J of the Virginia Retail Sales and Use Tax Regulations.

18. PROHIBITION AGAINST UNIFORM PRICING: The Purchasing Agent shall encourage open and competitive bidding by all possible means and shall endeavor to obtain the maximum degree of open competition on all purchase transactions using the competitive sealed bidding, competitive negotiation, or open market methods of procurement. In submitting a bid each bidder shall, by virtue of submitting a bid, guarantee that he or she has not been a party with other bidders to an agreement to bid a fixed or uniform price. Violation of this implied guarantee shall render void the bids of participating bidders. Any disclosure to or acquisition by a competitive bidder, in advance of the opening of the bids, of the terms or conditions of the bid submitted by another competitor may render the entire proceedings void and may require re-advertising for bids.

SPECIFICATIONS

19. QUESTIONS CONCERNING SPECIFICATIONS: Any information relative to interpretation of specifications and drawings shall be requested of the Purchasing Agent, in writing, in ample time before the opening of bids. No inquiries, if received by the Purchasing Agent within five (5) days of the date set for the opening of bids, will be given any consideration. Any material interpretation of a specification, as determined by the Purchasing Agent, will be expressed in the form of an addendum to the specification which will be sent to all prospective bidders no later than three (3) days before the date set for receipt of bids. Oral answers will not be authoritative.

20. BRAND NAME OR EQUAL ITEMS: Unless otherwise provided in the IFB, the name of a certain brand, make or manufacturer does not restrict bidders to the specific brand, make or manufacturer named; it conveys the general style, type, character, and quality of the article desired, and any article which the Authority in its sole discretion determines to be the equal of that specified, considering quality, workmanship, economy of operation, and suitability for the purpose intended, shall be accepted.

21. FORMAL SPECIFICATIONS: When a solicitation contains a specification which states no substitutes, no deviation therefrom will be permitted and the bidder will be required to furnish articles in conformity with that specification.

The bidder shall abide by and comply with the true intent of the specifications and not take advantage of any unintentional error or omission, but shall fully complete every part as the true intent and meaning of the specifications and drawings. Whenever the mention is made of any articles, material, or workmanship to be in accordance with laws, ordinances, building codes, underwriter's codes, A.S.T.M. regulations or similar expressions, the requirements of these laws, ordinances, etc., shall be construed as to the minimum requirements of these specifications.

22. FEDERAL SPECIFICATIONS: Any Federal Specifications referred to herein may be obtained

GENERAL CONDITIONS AND INSTRUCTIONS TO BIDDERS (Continued)

from the GSA Federal Supply Service Bureau - Specification Section, 470 East L'Enfant Plaza, S.W., Suite #8100, Washington, D.C. 20407 (Voice: 1-202-619-8925, Fax: 1-202-619-8978).

AWARD

23. AWARD OR REJECTION OF BIDS: The Purchasing Agent shall award the contract to the lowest responsive and responsible bidder complying with all provisions of the IFB, provided the bid price is reasonable and it is in the best interest of the Authority to accept it. Awards made in response to a RFP will be made to the highest qualified offeror whose proposal is determined, in writing, to be the most advantageous to the Authority taking into consideration the evaluation factors set forth in the RFP. The Purchasing Agent reserves the right to award a contract by individual items, in the aggregate, or in combination thereof, or to reject any or all bids and to waive any informality in bids received whenever such rejection or waiver is in the best interest of the Authority. Award may be made to as many bidders as deemed necessary to fulfill the anticipated requirements of the Authority. The Purchasing Agent also reserves the right to reject the bid of a bidder deemed to be a non-responsible bidder.

In determining the responsibility of a bidder, the following criteria will be considered:

- a. The ability, capacity and skill of the bidder to perform the contract or provide the service required;
- b. Whether the bidder can perform the contract or provide the service promptly, or within the time specified, without delay or interference;
- c. The character, integrity, reputation, judgment, experience and efficiency of the bidder;
- d. The quality of performance of previous contracts or services;
- e. The previous and existing compliance by the bidder with laws and ordinances relating to the contract or services;
- f. The sufficiency of the financial resources and ability of the bidder to perform the contract or provide the service;
- g. The quality, availability and adaptability of the goods or services to the particular use required;
- h. The ability of the bidder to provide future maintenance and service for the use of the subject of the contract;
- i. The number and scope of the conditions attached to the bid;
- j. Whether the bidder is in arrears to the Authority on debt or contract or is a defaulter on surety to the Authority or whether the bidder's taxes or assessments are delinquent; and
- k. Such other information as may be secured by the Purchasing Agent having a bearing on the decision to award the contract. If an apparent low bidder is not awarded a contract for reasons of non-responsibility, the Purchasing Agent shall so notify that bidder and shall have recorded the reasons in the contract file.

GENERAL CONDITIONS AND INSTRUCTIONS TO BIDDERS (Continued)

24. NOTICE OF ACCEPTANCE/CONTRACT DOCUMENTS: A written award (or Acceptance Agreement) mailed (or otherwise furnished) to the successful bidder within the time for acceptance specified in the solicitation shall be deemed to result in a binding contract. The following documents which are included in the solicitation shall be incorporated by reference in the resulting contract and become a part of said contract:

- a. Solicitation Form/Acceptance Agreement (Cover Sheet) and other documents which may be incorporated by reference (if applicable);
- b. General Conditions and Instructions to Bidders;
- c. Special Provisions and Specifications;
- d. Pricing Schedule; and
- e. Any Addenda/Amendments/Memoranda of Negotiations.

25. TIE-BIDS: If all bids are for the same total amount or unit price (including authorized discounts and delivery times), and if the public interest will not permit the delay of re-advertisement for bids, the Purchasing Agent is authorized to award the contract to the city of Alexandria resident tie bidder whose firm has its principal place of business in the city of Alexandria, or if there be none, to the resident Virginia tie bidder, or if there be none, to one of the tie bidders by drawing lots in public; or the Purchasing Agent may purchase the goods or services in the open market except that the price paid shall not exceed the lowest contract bid price submitted for the same goods or services. The decision of the Authority to make award to one or more such bidders shall be final.

26. PROMPT PAYMENT DISCOUNT:

- a. Unless otherwise specified in the solicitation, prompt payment discounts requiring payment in less than fifteen (15) days will not be considered in evaluating a bid for award. However, even though not considered in the evaluation, such discounts will be taken if payment is to be made within the discount period.
- b. In connection with any discount offered, time will be computed from the date of delivery of the supplies to the carrier when delivery, inspection and acceptance are at the point of origin; or, from date of delivery, inspection and acceptance at destination; or, from date correct invoice or voucher is received in the office specified by the Authority, if the latter is later than the date of acceptance. In the event the bidder does not indicate a prompt payment discount, it shall be construed to mean NET thirty (30) days.
- c. For the purpose of earning the discount, payment is deemed to be made as of the date of mailing of the Authority's check or issuance of an Electronic Funds Transfer.
- d. To subcontractors:
 - i. The Contractor shall take one of the two following actions within seven (7) days after receipt of amounts paid to the Contractor by the Authority for work performed by the subcontractor under the Contract: (a) pay the subcontractor for the proportionate share of the total payment received from the Authority attributable to the work performed by

GENERAL CONDITIONS AND INSTRUCTIONS TO BIDDERS (Continued)

- the subcontractor under the contract; or (b) notify the Authority and the subcontractor, in writing, of the Contractor's intention to withhold all or a part of the subcontractor's payment with the reason for nonpayment.
- ii. The Contractor shall pay interest to the subcontractor on all amounts owed by the Contractor that remain unpaid after seven (7) days following receipt by the Contractor of payment from the Authority for work performed by the subcontractor under the contract, except for amounts withheld as allowed in Section 26(C)(i).
 - iii. Unless otherwise provided under the terms of the contract, interest shall accrue at the rate of 0.5% per month. The Contractor shall include in each of its subcontracts a provision requiring each subcontractor to include or otherwise be subject to the same payment and interest requirements with respect to each lower-tier subcontractor.
- d. The Contractor's obligation to pay an interest charge to a subcontractor pursuant to this Section 26(C) shall not be construed to be an obligation of the Authority. A contract modification shall not be made for the purpose of providing reimbursement for the interest charge. A cost reimbursement claim shall not include any amount for reimbursement for the interest charge.

27. INSPECTION & ACCEPTANCE: For determining acceptance of supplies in accordance with the provisions of the prompt payment discount paragraph, inspection and acceptance shall be accomplished only after examination (including testing) of supplies and services to determine whether the supplies and services conform to the contract requirements. Acceptance shall occur only after receipt and inspection provided such inspection, as appropriate, is accomplished within a reasonable time.

28. DEFINITE BID QUANTITIES: Where definite quantities are specifically stated, acceptance will bind the Authority to order quantities specified and to pay for, at contract prices, all such supplies or services delivered that meet specifications and conditions of the contract. However, the Authority will not be required to accept delivery of any balances unordered, as of the contract expiration date, unless the Contractor furnished the Purchasing Agent with a statement of unordered balances not later than ten (10) days after the termination date of the contract.

29. REQUIREMENT BID QUANTITIES: On "Requirement" bids, acceptance will bind the Authority to pay for, at unit bid prices, only quantities ordered and delivered. Where the Authority specifies estimated quantities, the Contractor shall not be required to deliver more than ten (10%) percent in excess of the estimated quantity of each item, unless otherwise agreed upon.

CONTRACT PROVISIONS

30. TERMINATION OF CONTRACTS: Contracts will remain in force for full periods specified and/or until all articles ordered before date of termination shall have been satisfactorily delivered and accepted and thereafter until all requirements and conditions shall have been met, unless:

- a. Terminated prior to expiration date by satisfactory deliveries of entire contract requirements, or upon termination by the Authority for convenience or cause; or
- b. Extended upon written authorization of the Purchasing Agent and accepted by Contractor, to permit ordering of unordered balances or additional quantities at contract prices and in accordance with contract terms.

GENERAL CONDITIONS AND INSTRUCTIONS TO BIDDERS (Continued)

31. TERMINATION FOR CONVENIENCE: A contract may be terminated in whole or in part by the Authority in accordance with this clause whenever the Purchasing Agent shall determine that such a termination is in the best interest of the Authority. Any such termination shall be effected by delivery to the Contractor at least fifteen (15) days prior to the termination date of a written Notice of Termination specifying the extent to which performance shall be terminated and the date upon which termination becomes effective. An equitable adjustment in the contract price shall be made for completed service, but no amount shall be allowed for anticipated profit on unperformed services or for damages in connection therewith.

32. TERMINATION OF CONTRACT FOR CAUSE: If, through any cause: (i) the Contractor shall fail to fulfill in a timely and proper manner his or her obligations under this contract; (ii) if the Contractor becomes insolvent, or makes an assignment for the benefit of its creditors, or if a petition in bankruptcy is filed by or with respect to Contractor; or (iii) if the Contractor shall violate any of the covenants, agreements, or stipulations of this contract, the Authority shall thereupon have the right to terminate, specifying the effective date thereof, at least five (5) days before the effective date of such termination. In the event of a termination for cause, the Authority shall not be liable to the Contractor for payment of any amount beyond the value of any conforming goods and services shipped or received and accepted by the Authority, less damages suffered by the Authority. In such case, the Contractor shall be liable to the Authority for any and all losses, costs and damages incurred by the Authority arising out of or resulting from such default, including any and all liquidated damages which shall be based on the dates(s) that a reasonable substitute supplier, exercising proper due diligence, achieved such respective scheduled deliveries.

33. CONTRACT ALTERATIONS: No alterations in the terms of a contract shall be valid or binding upon the Authority unless made in writing and signed by the Purchasing Agent or his or her authorized agent.

34. SUBLETTING OF CONTRACT OR ASSIGNMENT OF CONTRACT FUNDS: It is mutually understood and agreed that the Contractor shall not assign, transfer, convey, sublet or otherwise dispose of his or her contractual duties to any other person, firm or corporation, without the previous written consent of the Purchasing Agent. If the Contractor desires to assign his or her right to payment of the contract, Contractor shall notify the Purchasing Agent immediately, in writing, of such assignment of right to payment. In no case shall such assignment of contract relieve the Contractor from his or her obligations or change the terms of the contract.

35. FUNDING: A contract shall be deemed binding only to the extent of appropriations available to the Authority for the purchase of goods and services.

36. DELIVERY/SERVICE FAILURES: Failure of a Contractor to deliver goods or services within the time specified, or within reasonable time as interpreted by the Purchasing Agent, or failure to make replacements/corrections of rejected articles/services when so requested, immediately or as directed by the Purchasing Agent, shall constitute authority for the Purchasing Agent to purchase in the open market articles/services of comparable grade/quality to replace the services, articles rejected, and/or not delivered. On all such purchases, the Contractor shall reimburse the Authority, within a reasonable time specified by the Purchasing Agent, for any expense incurred in excess of contract prices. Such purchases shall be deducted from the contract quantities if applicable. Should public necessity demand it, the Authority reserves the right to use or consume articles delivered or services performed which are substandard in quality, subject to an adjustment in price to be determined by the Purchasing Agent.

GENERAL CONDITIONS AND INSTRUCTIONS TO BIDDERS (Continued)

37. NON-LIABILITY: The Contractor shall not be liable in damages for delay in shipment or failure to deliver when such delay or failure is the result of fire, flood, strike, the transportation carrier, act of God, act of Government, act of an alien enemy or by any other circumstances which, in the Purchasing Agent's opinion, are beyond the control of the Contractor. Under such circumstances, however, the Purchasing Agent may, at his or her discretion, cancel the contract.

38. NEW GOODS, FRESH STOCK: All Contractors, unless otherwise specifically stated, shall provide new commodities, fresh stock, latest model, design or pack.

39. NON-DISCRIMINATION: During the performance of this contract, the Contractor agrees as follows:

- a. The Contractor will not discriminate against any employee or applicant for employment because of race, religion, color, sex, national origin, age, disability, or other basis prohibited by state law relating to discrimination in employment, except where there is a bona fide occupational qualification reasonably necessary to the normal operation of the Contractor. The Contractor agrees to post in conspicuous places, available to employees and applicants for employment, notices setting forth the provisions of this non-discrimination clause.
- b. The Contractor, in all solicitations or advertisements for employees placed by or on behalf of the Contractor, will state that such Contractor is an equal opportunity employer.
- c. Notices, advertisements and solicitations placed in accordance with federal law, rule or regulation shall be deemed sufficient for the purpose of meeting the requirements of this section.
- d. The Contractor will include the provisions of the foregoing paragraphs a, b, and c above in every subcontract or purchase order of over \$10,000 so that the provisions will be binding upon each subcontractor or vendor.
- e. The Authority does not discriminate against faith-based organizations.
- f. A faith-based organization contracting with the Authority: (i) shall not discriminate against any recipient of goods, services, or disbursements made pursuant to a contract authorized by Va. Code § 2.2-4343.1 on the basis of the recipient's religion, religious belief, refusal to participate in a religious practice, or on the basis of race, age, color, gender or national origin; and (ii) shall be subject to the same rules as other organizations that contract with public bodies to account for the use of the funds provided; however, if the faith-based organization segregates public funds into separate accounts, only the accounts and programs funded with public funds shall be subject to audit by the public body. Nothing in clause (ii) shall be construed to supersede or otherwise override any other applicable state law.
- g. Consistent with the Personal Responsibility and Work Opportunity Reconciliation Act of 1996, P.L. 104-193, funds provided for expenditure pursuant to contracts with public bodies shall not be spent for religious worship, instruction, or proselytizing; however, this prohibition shall not apply to expenditures pursuant to contracts, if any, for the services of chaplains.
- h. Nothing in this section shall be construed as barring or prohibiting a faith-based organization from any opportunity to make a bid or proposal or contract on the grounds that

GENERAL CONDITIONS AND INSTRUCTIONS TO BIDDERS (Continued)

the faith-based organization has exercised the right, as expressed in 42 U.S.C. (§ 2000 e-1 et seq.), to employ persons of a particular religion.

- i. The Authority shall provide to each individual who applies for or receives goods, services, or disbursements provided pursuant to a contract between a public body and a faith-based organization a notice in bold face type that states: "Neither the public body's selection of a charitable or faith-based provider of services nor the expenditure of funds under this contract is an endorsement of the provider's charitable or religious character, practices, or expression. No provider of services may discriminate against you on the basis of religion, a religious belief, or your refusal to actively participate in a religious practice. If you object to a particular provider because of its religious character, you may request assignment to a different provider. If you believe that your rights have been violated, please discuss the complaint with your provider or notify the appropriate person as indicated in this form."

40. OFFICE OF SMALL BUSINESS:

- a. It is the policy of the Authority that the Authority and its employees undertake every effort to increase opportunity for utilization of small or minority businesses in all aspects of procurement to the maximum extent feasible.
- b. In connection with the performance of this contract, the Contractor agrees to use his or her best effort to carry out this policy and to ensure that small and minority businesses shall have the maximum practicable opportunity to compete for subcontract work under this contract consistent with the efficient performance of this contract.
- c. As used in this contract the term "small business" means a corporation, partnership, or sole proprietorship, or other legal entity formed for the purpose of making a profit, which is independently owned and operated, has either fewer than 100 employees, or less than \$1,000,000 in annual receipts.
- d. As used in this contract, the term "minority business" means a business enterprise that is at least 51 percent owned and controlled by a minority person or persons. Such persons include African Americans, Hispanic Americans, Asian Americans, American Indians, Eskimos and Aleuts; women regardless of race or ethnicity; and persons with a physical impairment that substantially limits one or more of the major life activities of such individuals, a record of such impairment, or who are regarded as having such an impairment.
- e. Contractors may rely on oral or written representations by subcontractors regarding their status as small and/or minority business enterprises in lieu of independent investigation.
- f. Where Federal grants or monies are involved it is the policy of the Authority, through its agents and employees, to comply with the requirements set forth in the U.S. Office of Management and Budget Circular No. A-102, uniform administrative requirements for Grants and Cooperative Agreements with State and Local Governments, as they pertain to small and minority business utilization.

41. GUARANTEES & WARRANTIES: All guarantees and warranties required shall be furnished by the Contractor and shall be delivered to the Purchasing Agent before final payment on the contract is made. Unless otherwise stated, manufacturer's standard warranty applies.

GENERAL CONDITIONS AND INSTRUCTIONS TO BIDDERS (Continued)

42. PRICE REDUCTION:

- a. If at any time after the date of the bid the Contractor makes a general price reduction in the comparable price of any material covered by the contract to customers generally, an equivalent price reduction based on similar quantities and/or considerations shall apply to this contract for the duration of the contract period (or until the price is further reduced). Such price reduction shall be effective at the same time and in the same manner as the reduction in the price to customers generally. For purpose of this provision, a "general price reduction" shall mean any horizontal reduction in the price of an article or service offered: (i) to Contractor's customers generally; or (ii) in the Contractor's price schedule for the class of customers, i.e., wholesalers, jobbers, retailers, etc., which was used as the basis for bidding on this solicitation. An occasional sale at a lower price, or sale of distressed merchandise at a lower price, would not be considered a "general price reduction" under this provision. The Contractor shall submit his or her invoice at such reduced prices indicating on the invoice that the reduction is pursuant to the "Price Reduction" provision of the contract documents. The Contractor in addition will within ten days of any general price reduction notify the Purchasing Agent of such reduction by letter. **FAILURE TO DO SO MAY REQUIRE TERMINATION OF THE CONTRACT.** Upon receipt of any such notice of a general price reduction, all ordering offices will be duly notified by the Purchasing Agent.
- b. The Contractor, if requested, shall furnish, within ten (10) days after the end of the contract period, a statement certifying either: (a) that no general price reduction, as defined above, was made after the date of the bid; or (b) if any such general price reductions were made, that as provided above, they were reported to the Purchasing Agent within ten (10) days and ordering offices were billed at the reduced prices. Where one or more such general price reductions were made, the statement furnished by the Contractor shall include with respect to each price reduction (a) the date when notice of any such reduction was issued, (b) the effective date of the reduction, and (3) the date when the Purchasing Agent was notified of any such reduction.

43. CHANGES: Should it become proper or necessary in the execution of this contract to make any change in design or to make any alterations which will increase the expense, the Purchasing Agent shall determine an equitable adjustment. No payment shall be made to the Contractor for any extra material or services, or of any greater amount of money than stipulated to be paid in the contract, unless some changes in or additions to the contract requiring additional outlay by the Contractor shall first have been expressly authorized and ordered in writing by contract amendment or otherwise furnished by the Purchasing Agent.

44. PLACING OF ORDERS: Orders against contracts will be placed with the Contractor on a purchase order (or Procurement Card) executed and released by the Purchasing Agent or his or her designee. The purchase order must bear the appropriate contract number and date. Where Blanket Purchase Agreements (BPAs) have been executed and a blanket purchase order has been released by the Purchasing Agent, telephonic orders may be placed directly with the Contractor by authorized personnel in the ordering Agency.

DELIVERY PROVISIONS

45. SHIPPING INSTRUCTIONS - CONSIGNMENT: Unless otherwise specified in the solicitation each case, crate, barrel, package, etc., delivered under the contract must be plainly stenciled or

GENERAL CONDITIONS AND INSTRUCTIONS TO BIDDERS (Continued)

securely tagged, stating the Contractor's name, purchase order number, and delivery address as indicated in the order. Where shipping containers are to be used, each container must be marked with the purchase order number, name of the Contractor, the name of the item, the item number, and the quantity contained therein. Deliveries must be made within the hours of 8:00 AM - 3:00 PM. Deliveries at any other time will not be accepted unless specific arrangements have been previously made with the receiver at the delivery point. No deliveries will be accepted on Saturdays, Sundays and holidays, unless previous arrangements have been made. It shall be the responsibility of the Contractor to insure compliance with these instructions for items that are drop-shipped.

46. RESPONSIBILITY FOR SUPPLIES TENDERED: Unless otherwise specified in the solicitation, the Contractor shall be responsible for the materials or supplies covered by the contract until they are delivered at the designated point, but the Contractor shall bear all risk on rejected materials or supplies after notice of rejection. Rejected materials or supplies must be removed by and at the expense of the Contractor promptly after notification of rejection, unless public health and safety require immediate destruction or other disposal of rejected delivery. If rejected materials are not removed by the Contractor within ten (10) days after date of notification, the Authority may return the rejected materials or supplies to the Contractor at his or her risk and expense or dispose of them as its own property.

47. INSPECTIONS: Inspection and acceptance of materials or supplies will be made after delivery at destinations herein specified unless otherwise stated. If inspection is made after delivery at destination herein specified, the Authority will bear the expense of inspection except for the value of samples used in case of rejection. Final inspection shall be conclusive except in regard to latent defects, fraud or such gross mistakes as to amount to fraud. Final inspection and acceptance or rejection of the materials or supplies will be made as promptly as practicable, but failure to inspect and accept or reject materials or supplies shall not impose liability on the Authority for such materials or supplies as are not in accordance with the specifications.

48. COMPLIANCE: Delivery must be made as ordered and in accordance with the solicitation or as directed by the Purchasing Agent when not in conflict with the bid. The decision of the Purchasing Agent as to reasonable compliance with delivery terms shall be final. Burden of proof of delay in receipt of goods by the purchaser shall rest with the Contractor. Any request for extension of time of delivery from that specified must be approved by the Purchasing Agent, such extension applying only to the particular item or shipment affected. Should the Contractor be delayed by the Authority, there shall be added to the time of completion a time equal to the period of such delay caused by the Authority. However, the Contractor shall not be entitled to claim damages or extra compensation for such delay or suspension. These conditions may vary for construction contracts. See Special Provisions for the individual solicitation.

49. POINT OF DESTINATION: All materials shipped to the Authority must be shipped F.O.B. DESTINATION unless otherwise stated in the contract or purchase order. The materials must be delivered to the "Ship to" address indicated on the purchase order.

50. ADDITIONAL CHARGES: Unless bought F.O.B. "shipping point" and Contractor prepays transportation, no delivery charges shall be added to invoices except when express delivery is authorized and substituted on orders for the method specified in the contract. In such cases, difference between freight or mail and express charges may be added to invoice.

51. METHOD AND CONTAINERS: Unless otherwise specified, goods shall be delivered in

GENERAL CONDITIONS AND INSTRUCTIONS TO BIDDERS (Continued)

commercial packages in standard commercial containers, so constructed as to ensure acceptance by common or other carrier for safe transportation to the point of delivery. Containers become the property of the Authority unless otherwise specified by bidder.

52. WEIGHT CHECKING: Deliveries shall be subject to re-weighing over official sealed scales designated by the Authority. Payments shall be made on the basis of net weight of materials delivered. Normal shrinkage may be allowed in such instances where shrinkage is possible. Net weights only, exclusive of containers or wrapping, shall be paid for by the Authority.

53. DEMURRAGE AND RE-SPOTTING: The Authority will be responsible for demurrage charges only when such charges accrue because of the Authority's negligence in unloading the materials. The Authority will pay railroad charges due to the re-spotting of cars, only when such re-spotting is ordered by the Authority.

54. REPLACEMENT: Materials or components that have been rejected by the Purchasing Agent, in accordance with the terms of a contract, shall be replaced by the Contractor at no cost to the Authority.

55. PACKING SLIPS OR DELIVERY TICKETS: All shipments shall be accompanied by Packing Slips or Delivery Tickets and shall contain the following information for each item delivered:

1. The Purchase Order Number;
2. The Name of the Article and Stock Number (Supplier's);
3. The Authority's Identification Number (AIN), if specified in the order;
4. The Quantity Ordered;
5. The Quantity Shipped;
6. The Quantity Back Ordered; and
7. The Name of the Contractor.

Contractors are cautioned that failure to comply with these conditions shall be considered sufficient reason for refusal to accept the goods.

BILLING

56. BILLING: Unless otherwise specified on the contract or purchase order, invoices are to be submitted, in DUPLICATE, for each purchase order immediately upon completion of the shipment or services. If shipment is made by freight or express, the original Bill of Lading, properly receipted, must be attached to the invoice. Invoices should be mailed to the "BILL TO" address on the purchase order or to the appropriate address specified in the contract.

PAYMENTS

57. PAYMENT: Payment shall be made after satisfactory performance of the contract, in accordance with all of the provisions thereof, and upon receipt of a properly completed invoice. The Authority reserves the right to withhold any or all payments or portions thereof for Contractor's failure to perform in accordance with the provision of the contract or any modifications thereto.

58. PARTIAL PAYMENTS: Unless otherwise specified, partial payments will be made upon acceptance of materials or services so invoiced if in accordance with completion date. However, up to five (5%) percent of the value of the entire order may be retained until completion of contract.

GENERAL CONDITIONS AND INSTRUCTIONS TO BIDDERS (Continued)

59. PAYMENT FOR EQUIPMENT, INSTALLATION, AND TESTING: When equipment requires installation (which shall also be interpreted to mean erection and/or setting up or placing in position, service, or use) and test, and where such installation or testing is delayed, payment may be made on the basis of 50% of the contract price when such equipment is delivered on the site. A further allowance of 25% may be made when the equipment is installed and ready for test. The balance shall be paid after the equipment is tested and found to be satisfactory. If the equipment must be tested, but installation is not required to be made by the Contractor or if the equipment must be installed but testing is not required, payment may be made on the basis of 75% at the time of delivery and the balance shall be paid after satisfactory test or installation is completed.

GENERAL

60. GENERAL GUARANTY: Contractor agrees to:

- a. Save the Authority, its agents and employees harmless from liability of any nature or kind for the use of any copyrighted or uncopyrighted composition; secret process, patented or unpatented; invention; article or appliance furnished or used in the performance of a contract for which the Contractor is not the patentee, assignee, licensee or owner.
- b. Protect the Authority against latent defective material or workmanship and to repair or replace any damages or marring occasioned in transit or delivery.
- c. Furnish adequate protection against damage to all work and to repair damages of any kind to the building or equipment, to his or her own work or to the work of other contractors, for which his or her workers are responsible.
- d. Pay for all permits, licenses and fees and give all notices and comply with all laws, ordinances, rules and regulations of the Authority.
- e. Protect the Authority from loss or damage to the Authority owned property while it is in the custody of the Contractor.

61. SERVICE CONTRACT GUARANTY: Contractor agrees to:

- a. Furnish services described in the solicitation and resultant contract at the times and places and in the manner and subject to conditions therein set forth provided that the Authority may reduce the said services at any time.
- b. Enter upon the performance of services with all due diligence and dispatch, assiduously press to its complete performance, and exercise therein the highest degree of skill and competence.
- c. All work and services rendered in strict conformance to all laws, statues, and ordinances and the applicable rules, regulations, methods and procedures of all government boards, bureaus, offices and other agents.
- d. Allow services to be inspected or reviewed by an employee of the Authority at any reasonable time and place selected by the Authority. The Authority shall be under no obligation to compensate Contractor for any services not rendered in strict conformity with

GENERAL CONDITIONS AND INSTRUCTIONS TO BIDDERS (Continued)

the contract.

- e. Stipulate that the presence of an Authority Inspector shall not lessen the obligation of the Contractor for performance in accordance with the contract requirements, or be deemed a defense on the part of the Contractor for infraction thereof. The Inspector is not authorized to revoke, alter, enlarge, relax, or release any of the requirements of the contract documents. Any omission or failure on the part of the Inspector to disapprove or reject any work or material shall not be construed to be an acceptance of any such defective work or material. Notification of an omission or failure will be documented by the Purchasing Agent.

62. REPLACEMENT PRODUCTS/SERVICES:

- a. If the Authority determines that any product it receives from the Contractor is: (i) damaged; (ii) defective; (iii) fails to meet any specifications provided by the Authority; or (iv) fails to meet the Contractor's published specifications, then the Contractor must promptly repair or replace the product, upon written notice by the Authority which is delivered to the Contractor within twenty (20) days after the date of delivery, at no additional cost to the Authority. At the Authority's option, non-conforming products may be repaired or replaced by the Contractor at the Authority's facility or wherever the goods are located, or may be returned to the Contractor's facility or to an authorized repair center, all at the Contractor's expense. In the event of the Contractor's failure to repair or replace any non-conforming products or diligently initiate the correction, replacement or re-performance thereof within five (5) business days after the date of the Authority's notice to the Contractor, the Authority will have the right to correct or replace such products and to charge the Contractor all costs thereof. The cost of correction will be deducted from any amounts then or thereafter due the Contractor hereunder and, if such amounts are insufficient to cover the cost of correction, the Contractor will pay such deficiency to the Authority promptly following written demand therefore. Notwithstanding the foregoing, if any non-conformity with a warranty materially affects the operation or use of any of the products or presents an imminent threat to the safety or health of any person or entity and the Authority knows of such non-conformity, the Authority may, at its option, correct or replace such products without giving the Vendor notice of such non-conformity, and the Vendor will be responsible and liable to the Authority for all costs incurred by the Authority.
- b. If, any services do not conform in all material respects to the representations and warranties set forth in any specifications provided by the Authority or the Contractor's published specifications, upon written notice by the Authority which is delivered to the Contractor within twenty (20) days after the date of performance, the Contractor will, at the Authority's sole discretion: (i) re-perform the service to the satisfaction of the Authority at no additional cost to the Authority; or (ii) refund to the Authority the full amount paid by the Authority.

63. INDEMNIFICATION: The Contractor hereby assumes all risks associated with furnishing the products and services specified herein and agrees to defend, indemnify and hold the Authority and its directors, officers, employees, agents, contractors, and sub-contractors (collectively, the "Authority Indemnitees") harmless from and against all claims, losses, costs, liabilities, demands, causes of action and expenses (including reasonable attorney's fees) suffered or incurred by the Authority Indemnitees arising out of, or in connection with: (a) any act or omission of the Contractor, its employees, officers, directors, agents, contractors or sub-contractors; (b) Contractor's failure to manufacture any item it provides to the Authority in accordance with any specifications provided by the Authority; (c) failure of any product or service to perform in

GENERAL CONDITIONS AND INSTRUCTIONS TO BIDDERS (Continued)

accordance with Contractor's published specifications; or (d) Contractor's failure to provide complete and accurate information regarding any product. The Contractor's duties under this provision will include the duty to obtain the approval of the Authority as to the legal counsel selected to defend the Authority and to confer with the Authority concerning the defense.

64. INTELLECTUAL PROPERTY RIGHTS:

The Contractor represents and warrants that all information it uses or relies upon in performing its services belongs to the Contractor or is information which the Contractor has the legal right to use. The Contractor further represents and warrants that any items it develops and manufacturing processes it uses or specifies will not violate or infringe against any existing patent, copyright, trademark, trade secret, or other intellectual property right. The Contractor agrees to indemnify and hold the Authority, its directors, officers, employees, agents, contractors, and sub-contractors (the "Authority Indemnitees") harmless from and against all claims, losses, costs, liabilities, demands, causes of action and expenses (including reasonable attorney's fees) suffered or incurred by the Authority arising out of, or in connection with, an allegation that the Contractor's item or service infringes any patent, copyright, trademark, trade secret or other intellectual property right. The Contractor's duties under this provision will include the duty to obtain the approval of the Authority as to the legal counsel selected to defend the Authority and to confer with the Authority concerning the defense.

65. OFFICIALS NOT TO BENEFIT:

- a. Each bidder or offeror shall certify upon signing a bid or proposal that, to the best of his or her knowledge, no Authority official or employee having official responsibility for the procurement transaction, or member of his or her immediate family, has received or will receive any financial benefit of more than nominal or minimal value relating to the award of this contract. If such a benefit has been received or will be received, this fact shall be disclosed with the bid or proposal or as soon thereafter as it appears that such a benefit will be received. Failure to disclose the information prescribed above may result in suspension or debarment, or rescission of the contract made, or could affect payment pursuant to the terms of the contract.
- b. Whenever there is reason to believe that a financial benefit of the sort described in paragraph "a" has been or will be received in connection with a bid, proposal or contract, and that the Contractor has failed to disclose such benefit or has inadequately disclosed it, the Authority Executive, as a prerequisite to payment pursuant to the contract, or at any other time, may require the Contractor to furnish, under oath, answers to any interrogatories related to such possible benefit.
- c. In the event the bidder or offeror has knowledge of benefits as outlined above, this information should be submitted with the bid or proposal. If the above does not apply at time of award of contract and becomes known after inception of a contract, the bidder or offeror shall address the disclosure of such facts to the Purchasing Agent, 1500 Eisenhower Ave., Alexandria, VA 22314. Relevant Invitation/RFP Number (see cover sheet) should be referenced in the disclosure.

66. LICENSE REQUIREMENTS: All firms doing business with the Authority shall obtain a business license as required by the Commonwealth of Virginia and the City of Alexandria. Questions concerning the "Business Professional and Occupational Licensing Tax" (BPOL Tax) should be

GENERAL CONDITIONS AND INSTRUCTIONS TO BIDDERS (Continued)

directed to (703) 746-3903 or visit <http://alexandriava.gov/finance/info/default.aspx?id=12680>. The BPOL Tax number must be indicated in the space provided on the Cover Sheet, "Alexandria License Tax No." when appropriate.

67. REGISTERING OF CORPORATIONS: Any foreign corporation transacting business in Virginia shall secure a certificate of authority as required by Section 13.1-757 of the Code of Virginia, from the State Corporation Commission, Post Office Box 1197, Richmond, Virginia 23209. The Commission may be reached at (804) 371-9733. The consequences of failing to secure a certificate of authority are set forth in Virginia Code Section 13.1-758. Contractor will be authorized to transact business in the Commonwealth as domestic or foreign business entity if so required by Title 13.1 or Title 50 of the Code of Virginia or as otherwise required by law, and contractor shall not allow this authorization to lapse or its certificate of authority or registration to transact business in Virginia, if so required under Title 13.1 or Title 50 of the Virginia Code, to be revoked or cancelled at any time during the term of this contract. To the extent required by the Commonwealth of Virginia (see 54.1-1100 et seq. of the Code of Virginia), the Contractor shall be duly licensed to provide the goods and services required to be delivered pursuant to this contract.

68. COVENANT AGAINST CONTINGENT FEES: The Contractor warrants that no person or selling agency has been employed or retained to solicit or secure this contract upon an agreement or understanding for a commission, percentage, brokerage, or contingent fee, except bona fide employees or bona fide established commercial or selling agencies maintained by the Contractor for the purpose of securing business. For violation of this warranty, the Authority shall have the right to terminate or suspend this contract without liability to the Authority or in its discretion to deduct from the contract price or consideration, or otherwise recover, the full amount of such commission, percentage, brokerage, or contingent fee.

69. VIRGINIA FREEDOM OF INFORMATION ACT: All proceedings, records, contracts and other public records relating to procurement transactions shall be open to the inspection of any citizen, or any interested person, firm or corporation, in accordance with the Virginia Freedom of Information Act except as provided below:

- a. Cost estimates relating to a proposed procurement transaction prepared by or for a public body shall not be open to public inspection.
- b. Any competitive sealed bidding bidder, upon request, shall be afforded the opportunity to inspect bid records within a reasonable time after the opening of all bids but prior to award, except in the event that the Authority decides not to accept any of the bids and to reopen the contract. Otherwise, bid records shall be open to public inspection only after award of the contract. Any competitive negotiation offeror, upon request, shall be afforded the opportunity to inspect proposal records within a reasonable time after the evaluation and negotiations of proposals are completed but prior to award except in the event that the Authority decides not to accept any of the proposals and to reopen the contract. Otherwise, proposal records shall be open to the public inspection only after award of the contract except as provided in paragraph "c" below. Any inspection of procurement transaction records under this section shall be subject to reasonable restrictions to ensure the security and integrity of the records.
- c. Trade secrets or proprietary information submitted by a bidder, offeror or contractor in connection with a procurement transaction or prequalification application submitted pursuant to the prequalification process identified in the Special Provisions, shall not be

GENERAL CONDITIONS AND INSTRUCTIONS TO BIDDERS (Continued)

subject to the Virginia Freedom of Information Act; however, the bidder, offeror or contractor shall: (i) invoke the protections of this section prior to or upon submission of the data or other materials; (ii) identify the data or other materials to be protected; and (iii) state the reasons why protection is necessary.

- d. Nothing contained in this section shall be construed to require the Authority, when procuring by "competitive negotiation" (Request for Proposal), to furnish a statement of the reasons why a particular proposal was not deemed to be the most advantageous to the Authority.

BIDDER/CONTRACTOR REMEDIES

70. INELIGIBILITY:

- a. Any person or firm suspended or debarred from participation in Authority procurement shall be notified in writing by the Purchasing Agent. Prior to the issuance of a written determination of disqualification or ineligibility, the Purchasing Agent shall: (i) notify the bidder, offeror or contractor in writing of the results of the evaluation; (ii) disclose the factual support for the determination; and (iii) allow the bidder, offeror or contractor an opportunity to inspect any documents that relate to the determination, if so requested by the bidder or contractor within five business days after receipt of the notice. Within ten business days after receipt of the notice, the bidder, offeror or contractor may submit rebuttal information challenging the evaluation. The Purchasing Agent shall issue its written determination or disqualification or ineligibility based on all information in the possession of the Authority, including any rebuttal information, within five business days after the date the public body received such rebuttal information. If the evaluation reveals that the bidder, offeror or contractor should be refused permission to participate, or disqualified from participation in, the contract, the Purchasing Agent shall so notify the bidder, offeror or contractor. The notice shall state the basis for the determination, which shall be final unless the bidder, offeror or contractor appeals the decision within ten days after receipt of the notice by instituting legal action as provided in the Code of Virginia.
- b. The Purchasing Agent shall have the authority to declare a person or firm ineligible or disqualified from bidding on or participating in any contract for the causes stated below:
 - i. Conviction for commission of a criminal offense as an incident to obtaining or attempting to obtain a public or private contract or subcontract, or in the performance of such contract or subcontract;
 - ii. Conviction under state or federal statutes of embezzlement, theft, forgery, bribery, falsification or destruction of records, receiving stolen property, or any other offense indicating a lack of business integrity or business honesty which currently, seriously, and directly affects responsibility as a contractor to the Authority;
 - iii. Conviction under the state or federal antitrust statutes arising out of the submission of bids or proposals;
 - iv. Violation of contract provisions, as set forth below, of a character which is regarded by the Purchasing Agent to be so serious as to justify suspension or debarment action:

GENERAL CONDITIONS AND INSTRUCTIONS TO BIDDERS (Continued)

- (a) failure without good cause to perform in accordance with the specifications or within the time limit provided in the contract; or
- (b) a recent record of failure to perform or of unsatisfactory performance in accordance with the terms of one or more contracts; provided, that failure to perform or unsatisfactory performance caused by acts beyond the control of the Contractor shall not be considered to be a basis for suspension or debarment;
- v. Any other cause the Purchasing Agent determines to be so serious and compelling as to affect responsibility as a Contractor, such as debarment by another governmental entity for any cause listed herein, or because of prior reprimands;
- vi. The Contractor has abandoned performance or been terminated for default on any other The Authority project;
- vii. The Contractor is in default on any surety bond or written guarantee on which the Authority is an obligee.
- c. If, upon appeal, it is determined that the action taken by the Purchasing Agent was arbitrary or capricious, or not in accordance with the Constitution of Virginia, statutes or regulations, the sole relief available to the person or firm shall be restoration of eligibility. The person or firm may not institute legal action until all statutory requirements have been met.

71. APPEAL OF DENIAL OF WITHDRAWAL OF BID:

- a. A decision denying withdrawal of a bid submitted by a bidder or offeror shall be final and conclusive unless the bidder appeals the decision within ten (10) days after receipt of the decision by instituting legal action as provided in the Code of Virginia. The bidder or offeror may not institute legal action until all statutory requirements have been met.
- b. If no bid bond was posted, a bidder refused withdrawal of bid, prior to appealing, shall deliver to the Authority a certified check or cash bond in the amount of the difference between the bid sought to be withdrawn and the next low bid. Such security shall be released only upon a final determination that the bidder was entitled to withdraw the bid.
- c. If, upon appeal, it is determined that the decision refusing withdrawal of the bid was arbitrary or capricious, the sole relief shall be withdrawal of the bid.

72. APPEAL OF DETERMINATION OF NONRESPONSIBILITY:

- a. Any bidder who, despite being the apparent low bidder, is determined not to be a responsible bidder for a particular contract with the Authority shall be notified in writing by the Purchasing Agent. Such notice shall state the basis for the determination, which shall be final unless the bidder appeals the decision within ten (10) days of receipt of the notice by instituting legal action as provided in the Code of Virginia. The bidder may not institute legal action until all statutory requirements have been met.
- b. If, upon appeal, it is determined that the decision of the Purchasing Agent was arbitrary or capricious and the award for the particular Authority contract in question has not been

GENERAL CONDITIONS AND INSTRUCTIONS TO BIDDERS (Continued)

made, the sole relief available to the bidder shall be a finding that the bidder is a responsible bidder for the contract with the Authority in question. Where the award has been made and performance has begun, the Authority may declare the contract void upon a finding that this action is in the best interest of the public. Where a contract is declared void, the Contractor shall be compensated for the cost of performance up to the time of such declaration. In no event shall the Contractor be entitled to lost profits.

73. PROTEST OF AWARD OR DECISION TO AWARD:

- a. Any bidder or offeror may protest the award or decision to award a contract by submitting a protest in writing to the Purchasing Agent, or an official designated by the Authority, no later than ten (10) days after the award or the announcement of the decision to award, whichever occurs first. Any potential bidder or offeror on a contract negotiated on a sole source or emergency basis who desires to protest the award or decision to award such contract shall submit such protest in the same manner no later than ten days after posting or publication of the notice of such contract. However, if the protest of any actual or potential bidder or offeror depends in whole or in part upon information contained in public records pertaining to the procurement transaction which are subject to inspection, then the time within which the protest must be submitted shall expire ten days after those records are available for inspection by such bidder or offeror, or at such later time as provided herein. No protest shall lie for a claim that the selected bidder or offeror is not a responsible bidder or offeror. The written protest shall include the basis for the protest and the relief sought. The Purchasing Agent shall issue a decision in writing within ten (10) days of the receipt of the protest stating the reasons for the action taken. This decision shall be final unless the bidder or offeror appeals within ten (10) days of receipt of the written decision by instituting legal action as provided in the Code of Virginia.
- b. If prior to award it is determined that the decision to award is arbitrary or capricious, then the sole relief shall be a finding to that effect. The Purchasing Agent shall cancel the proposed award or revise it to comply with the law. If, after an award, it is determined that an award of a contract was arbitrary or capricious, then the sole relief shall be as hereinafter provided. Where the award has been made but performance has not begun, the performance of the contract may be declared void by the Authority. Where the award has been made and performance has begun, the Purchasing Agent may declare the contract void upon a finding that this action is in the best interest of the Authority. Where a contract is declared void, the Contractor shall be compensated for the cost of performance at the rate specified in the contract up to the time of such declaration. In no event shall the Contractor be entitled to lost profits.
- c. Pending final determination of a protest or appeal, the validity of a contract awarded and accepted in good faith in accordance with this article shall not be affected by the fact that a protest or appeal has been filed.
- d. An award need not be delayed for the period allowed a bidder or offeror to protest, but in the event of a timely protest, no further action to award the contract will be taken unless there is a written determination that proceeding without delay is necessary to protect the public interest or unless the bid or offer would expire.

74. CONTRACTUAL DISPUTES:

GENERAL CONDITIONS AND INSTRUCTIONS TO BIDDERS (Continued)

- a. Any dispute concerning a question of fact as a result of a contract with the Authority which is not disposed of by agreement shall be decided by the Purchasing Agent, who shall reduce his decision to writing and mail or otherwise forward a copy thereof to the Contractor within ninety (90) days. The decision of the Purchasing Agent shall be final and conclusive unless the Contractor appeals within six (6) months of the date of the final written decision by instituting legal action as provided in the Code of Virginia. The Contractor may not institute legal action, prior to receipt of the public body's decision on the claim, unless the public body fails to render such decision within the time specified.
- b. Contractual claims, whether for money or other relief, shall be submitted in writing no later than sixty days after final payment; however, written notice of the Contractor's intention to file such claim shall have been given at the time of the occurrence or beginning of the work upon which the claim is based. Nothing herein shall preclude a contract from requiring submission of an invoice for final payment within a certain time after completion and acceptance of the work or acceptance of the goods. Pendency of claims shall not delay payment of amounts agreed due in the final payment.

75. LEGAL ACTION: No bidder, offeror, potential bidder or offeror, or contractor shall institute any legal action until all statutory requirements have been met.

76. COOPERATIVE PURCHASING: The Authority may participate in, sponsor, conduct or administer a cooperative procurement agreement on behalf of or in conjunction with one or more other public bodies, or public agencies or institutions or localities of the several states, of the United States or its territories, the District of Columbia or the U.S. General Services Administration, for the purpose of combining requirements to increase efficiency or reduce administrative expenses in any acquisition of goods and services. Except for contracts for professional services, a public body may purchase from another public body's contract even if it did not participate in the RFP or IFB, if the RFP or IFB specified that the procurement was being conducted on behalf of other public bodies. Nothing herein shall prohibit the assessment or payment by direct or indirect means of any administrative fee that will allow for participation in any such arrangement.

77. PROFESSIONAL AFFILIATION: The Authority holds membership in the National Institute of Governmental Purchasing, Inc., a non-profit, educational and technical organization that includes among its goals and objectives the study, discussion, and recommendation of improvements in governmental purchasing and the interchange of ideas and experiences on local state, and national governmental purchasing problems.

78. DRUG FREE WORKPLACE: During the performance of a contract, the Contractor agrees to: (a) provide a drug-free workplace for the Contractor's employees; (b) post in conspicuous places, available to employees and applicants for employment, a statement notifying employees that the unlawful manufacture, sale, distribution, dispensation, possession, or use of a controlled substance or marijuana is prohibited in the Contractor's workplace and specifying the actions that will be taken against employees for violations of such prohibition; (c) state in all solicitations or advertisements for employees placed by or on behalf of the Contractor that the Contractor maintains a drug-free workplace; and (d) include the provisions of the foregoing clauses in every subcontract of over \$10,000, so that the provisions will be binding upon each subcontractor or vendor. For the purposes of this section, "drug-free workplace" means a site for the performance of work done in conjunction with a specific contract awarded to a contractor in accordance with this section, the employees of whom are prohibited from engaging in the unlawful manufacture, sale, distribution, dispensation, possession or use of any controlled substance or marijuana during the

GENERAL CONDITIONS AND INSTRUCTIONS TO BIDDERS (Continued)

performance of the contract.

79. MATERIAL SAFETY DATA SHEETS: Contractor will provide the Authority with complete and accurate Material Safety Data Sheets (“MSDS”) for the goods and such additional information as is necessary for the safe handling and use of such goods. Contractor agrees that the Authority may rely upon the information provided by the Vendor when informing the Authority’s employees and customers about the risks associated with the goods and the safe handling and use of the goods.

80. INDEPENDENT CONTRACTOR: Contractor is an independent contractor and is not an employee or agent of the Authority. Contractor will provide services at such a place and in such time and manner as the Contractor deems appropriate. Contractor will not have the right to incur any obligations whatsoever on the part of the Authority.

81. FEDERAL IMMIGRATION LAW: Contractor does not, and will not, during its performance under this contract for good and services in the Commonwealth, knowingly employ an unauthorized alien as defined in the Federal Immigration and Reform and Control Act of 1986.

82. ETHICS IN PUBLIC CONTRACTING: The ethics in public contracting provisions of Sections 2.2-4367 through 2.2-4377 of the Code of Virginia are applicable to all contracts entered into by the Authority.

83. CHOICE OF LAW: This contract will be subject to and governed by the laws of the Commonwealth of Virginia. Any dispute arising hereunder which is not otherwise resolved by the parties herein shall be brought in a court of competent jurisdiction in the City of Alexandria, Virginia.

84. WAIVER: The Authority’s failure to insist upon the performance of any or all of the terms, covenants or conditions of this contract or failure to exercise any rights or remedies hereunder will not be construed as a waiver or relinquishment of the future performance of any such terms, covenants or conditions, or of the future exercise of such rights or remedies unless otherwise provided for herein.

85. SEVERABILITY: In the event that any one or more of the provisions contained in this contract will for any reason be held by a court of competent jurisdiction to be unenforceable in any respect, such holding will not affect any other provisions of this contract, and the contract will then be construed as if such unenforceable provisions are not a part hereof.

The following documents which are included in this Solicitation shall be incorporated by reference in the resulting contract and become a part of said contract:

- A. Alexandria Sanitation Authority Cover Sheet
- B. Special Provisions & Specifications
- C. Appendix A (General Conditions and Instructions to Bidders)
- D. Appendix B (Pricing Schedule, BPOL Form, Sample Jurisdiction Listing, SBE Schedule and Subcontractors Notification Form)

CONTACT FOR ADMINISTRATION:

NAME: _____

ADDRESS: (Office)_____

TELEPHONE/FAX: (Office)_____

E-MAIL:_____

PAY TO ADDRESS: (If different from Firm address on Cover Sheet)

PRICING SCHEDULE:

Item No.	Item Description	Qty	UOM	Unit Price	Extension
1	<p>TASKMASTER® GRINDERS, Model TM851208 as follows:</p> <p>Drop-in design housing for fast & easy maintenance without breaking pipe connections (ASA will use existing drive & control min: 75 GPM; max: 200)</p> <p>Cutter cartridge technology: patented, high strength tooth cam cutters, 4140 H.T.</p> <p>Nom. 8" x 12" cutting chamber</p> <p>8" ansi flange housing – 150# bolt pattern – D.1.</p> <p>Mechanical seals: TC vs. TC 90 psi max</p> <p>2" hexagonal shafting, 4140 H.T.</p> <p>23.25" flange to flange dimension</p>	3		\$ _____	\$ _____
2	<p>Gear Reducers Vertical down – flange mount For C face motor, less motor Ratio: 29:1 suitable for 3-5 hp</p>	3		\$ _____	\$ _____
3	<p>Reducer Adapters to fit existing motor (approx. height – 8 inches)</p>	3		\$ _____	\$ _____
4	<p>Expansion Joint Spool piece, 8" x 8" FF, superflex style 1000, neo tube & cover, reinforced SGL arch filled, 150#, drilled flanges with 8" 150# retaining rings and control units (2 rods)</p>	3		\$ _____	\$ _____
5	<p>Coupling Halfs for Reducers 3.75 OD 1.5 ID 3/8" key 3.19 length</p>	3		\$ _____	\$ _____

Delivery: _____ Calendar days after receipt of purchase order

Sample Listing of Local Public Bodies

REFERENCE PARAGRAPH 19 OF THE SPECIAL PROVISIONS, "USE OF CONTRACTS BY OTHER PUBLIC BODIES." You may select those public bodies that this contract may be extended:

Alexandria Public Schools, VA	Manassas Park, Virginia
Alexandria, Virginia	Manassas, Virginia
Arlington County, Virginia	Manassas City Public Schools, Virginia
Arlington Public Schools, Virginia	Maryland-National Capital Park & Planning Commission
Bowie, Maryland	Metropolitan Washington Airports Authority
Charles County, Maryland	Metropolitan Washington Council of Governments
Charles County Public Schools, MD	Montgomery Community College
Chevy Chase Village, MD	Montgomery County, Maryland
Clark County Administrative Services	Montgomery County Public Schools, MD
College Park, Maryland	Northern Virginia Community College
Culpeper County, Virginia	Northern Virginia Regional Commission
Culpeper County Public Schools	Orange County Public Schools, Virginia
District of Columbia	Prince George's County, Maryland
District of Columbia Courts	Prince George's County Public Schools, MD
DC Water and Sewer Authority	Prince William County Public Schools, VA
District of Columbia Schools	Prince William County, Virginia
Fairfax County Water Authority	Prince William County Service Authority
Fairfax, Virginia (City)	Rappahannock County Public Schools, VA
Fairfax, Virginia (County)	Rockville, Maryland
Falls Church City Public Schools	Shenandoah County Public Schools, VA
Falls Church, Virginia	Spotsylvania County Schools, Virginia
Fauquier County, Virginia	Stafford County, Virginia
Fauquier County Schools, Virginia	Stafford County Public Schools, Virginia
Fauquier County Water & Sanitation Authority	Takoma Park, Maryland
Frederick City, Maryland	Vienna, Virginia
Frederick County Maryland	Upper Occoquan Sewage Authority
Frederick County Schools, Maryland	Virginia Railway Express
Gaithersburg, Maryland	Washington Suburban Sanitary Commission
Greenbelt, Maryland	Washington Metropolitan Area Transit Authority
Herndon, Virginia	Winchester, Virginia
Leesburg, Virginia	Winchester Public Schools
Loudoun County Sanitation Authority	Others
Loudoun County, Public Schools, VA	
Loudoun County, Virginia	
Madison County Public Schools, VA	
Manassas Park Public Schools, VA	

YOU MUST RETURN THIS FORM WITH YOUR BID PACKAGE – A NEGATIVE REPLY WILL NOT AFFECT CONSIDERATION OF YOUR FIRM'S BID. CONTRACT AWARD SHALL NOT BE MADE WITHOUT THIS FORM.

Vendor Name

BUSINESS CLASSIFICATION SCHEDULE

DEFINITIONS

The Authority has established the following definitions for small and minority businesses:

Small Business/Organization – A business/organization that employs fewer than 100 full time employees or generates less than \$1,000,000 in annual gross sales.

Minority Business – A business enterprise that is at least **51%** owned and controlled by a minority person or persons. Such persons include African Americans, Hispanic Americans, Asian Americans, American Indians, Eskimos and Aleuts; Women (regardless of race or ethnicity); and persons with a physical impairment that substantially limits one or more of the major life activities of such individuals, a record of such impairment, or who are regarded as having such an impairment.

YOU MUST CLASSIFY YOUR BUSINESS/ORGANIZATION BY MARKING ONE (1) OF THE SIX (6) BOXES IN THE CHART BELOW. This designation is required of all business/organizations including publicly traded corporations, non-profits, sheltered workshops, government organizations, partnerships, sole proprietorships, etc.

Examples:

A small business, Asian woman owned, would mark box C on line 2.

A large business, African-American owned, would mark box V on line 3.

A small non-profit would mark box B on line 1.

A large business, publicly traded on NYSE or NASDAQ, would mark box Y on line 1.

<u>Line</u>	<u>SMALL BUSINESS</u>	<u>LARGE BUSINESS</u>	<u>OWNERSHIP</u>
1.	___ B	___ Y	Regardless of Ownership
2.	___ C	___ A	Women-Owned
3.	___ X	___ V	Minority-Owned

PLEASE RETURN THIS FORM WITH YOUR BID PACKAGE. CONTRACT AWARD MAY NOT BE MADE WITHOUT IT.

NAME OF FIRM: _____



ALEXANDRIA SANITATION AUTHORITY
 SMALL AND MINORITY BUSINESS ENTERPRISE PROGRAM (SMBEP)
 1500 Eisenhower Ave.
 Alexandria, VA 22314
 Tel: (703) 549-3381; Fax: (703) 549-9671
www.alexsan.org

SUBCONTRACTOR (S) NOTIFICATION FORM

Contract Number/Title: _____
 Prime Contractors Name: _____

Prime Contractor's Classification Code: _____ (from SBE Schedule)

In accordance with the Subcontracting Section of the Special Provisions for the above-cited contract, you are required to provide the Authority with names, addresses, anticipated dollar amount and small/minority classification (use code numbers from previous page) of each first-tier subcontractor. Please complete this form and return it to this office with your bid package.

Please check here if you are not using a subcontractor: ____

SUBCONTRACTOR(S) NAME	STREET ADDRESS	CITY	STATE	ZIP CODE	ANTICIPATED DOLLAR AMOUNT	SMALL/MINORITY CLASSIFICATION

YOU MUST RETURN THIS FORM WITH YOUR BID PACKAGE. CONTRACT AWARD SHALL NOT BE MADE WITHOUT IT.